

UTILITIES MODUS LFM

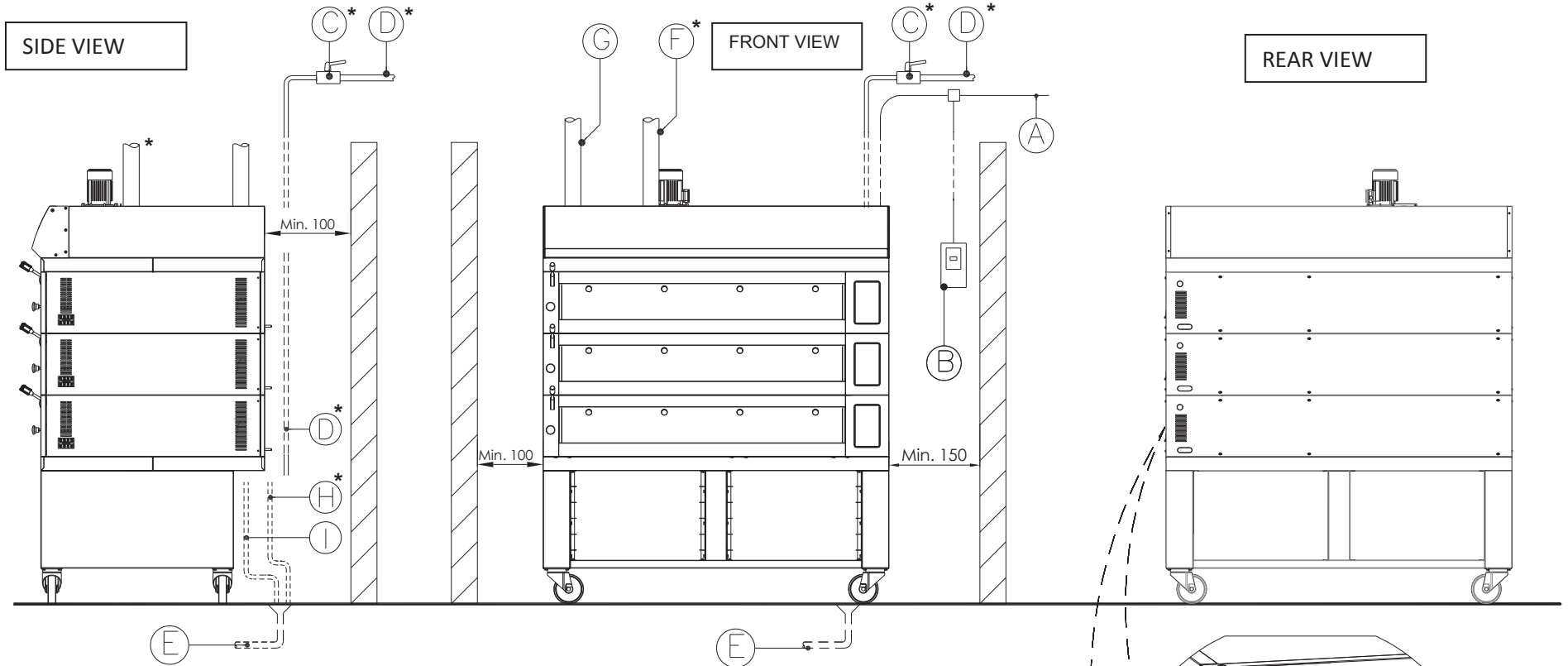

DESCRIPTION :

- A ELECTRIC LINE RSTN + EARTH
- B DISCONNECTING SWITCH
- C* WATER CUT OFF TAP
- D* WATER INLET PIPE Ø 1/2"
- E MAIN DRAIN PIPE Ø 40
- F* STEAM EXHAUST PIPE ON HOOD Ø 80mm
- G STEAM EXHAUST PIPE BAKING DECK Ø 80mm
- H* DRAIN FROM STEAM GENERATOR Ø 1/2"
- I DRAIN FROM BAKING DECK Ø 1/2"

* OPTIONAL

